

S P E C F I L E

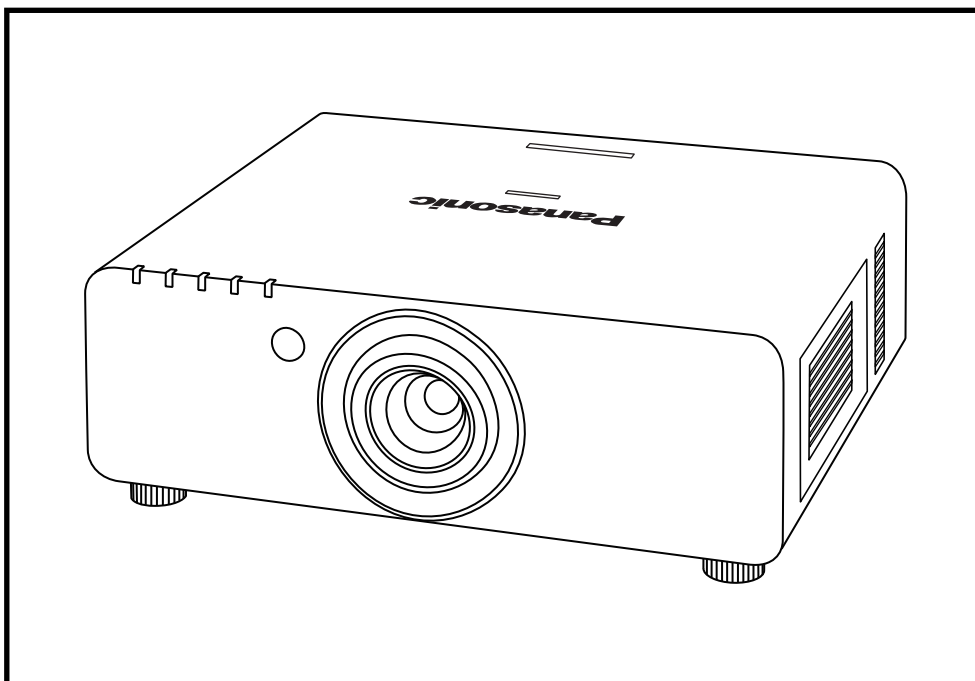

The PT-D5000LS is not equipped with a lens.

Product Number : **PT-D5000S/D5000LS**

Product Name : DLP™ Projectors

Specifications

Main Unit

Power supply:	North America:	120 V AC, 50/60 Hz
	Europe:	220–240 V AC, 50/60 Hz
Power consumption:	North America:	610 W (640 VA) (Standby mode eco*1: 0.2 W, Standby mode normal: 8 W. Both with fan stopped.)
	Europe:	600 W (670 VA) (Standby mode eco*1: 0.3 W, Standby mode normal: 9 W. Both with fan stopped.)
DLP™ chip:	Panel size:	0.7" diagonal (4:3 aspect ratio)
	Display method:	DLP™ chip x 1, DLP™ system
	Pixels:	786,432 (1,024 x 768) x 1, total of 786,432 pixels
Lens:	PT-D5000S:	Powered zoom/focus lenses (1.8–2.4:1), F 1.7–2.0, f 25.6–33.8 mm
	PT-D5000LS:	Optional poweredzoom/focus lenses
Lamp:		240 W UHM lamps (x 2) (dual lamp system)
Screen size:		50–600 inches (50–200 inches with the ET-DLE055), 4:3 aspect ratio
Brightness*2:		5,000 lumens (dual lamp)
Center-to-corner uniformity*2:		90%
Contrast*2:		1,000:1 (full on/full off)
Resolution:		1,024 x 768 pixels (Input signals that exceed this resolution will be converted to 1,024 x 768 pixels.)
Scanning frequency:	DVI-D:	Horizontal: 15–91 kHz, Vertical: 50–85 Hz, Dot clock: 162 MHz or lower
	RGB:	Horizontal: 15–91 kHz, Vertical: 50–85 Hz, Dot clock: 150 MHz or lower
	YPbPr (YCbCr):	525i (480i): fH 15.75 kHz; fV 60 Hz, 625i (576i): fH 15.63 kHz; fV 50 Hz, 525p (480p): fH 31.50 kHz; fV 60 Hz, 625p (576p): fH 31.25 kHz; fV 50 Hz, 750 (720)/60p: fH 45.00 kHz; fV 60 Hz, 750 (720)/50p: fH 37.50 kHz; fV 50 Hz, 1035/60i: fH 33.75 kHz; fV 60 Hz, 1125 (1080)/60i: fH 33.75 kHz; fV 60 Hz, 1125 (1080)/50i: fH 28.13 kHz; fV 50 Hz, 1080/25p: fH 28.13 kHz; fV 25 Hz, 1080/24p: fH 27.00 kHz; fV 24 Hz, 1080/24sF: fH 27.00 kHz; fV 48 Hz, 1080/30p: fH 33.75 kHz; fV 30 Hz, 1080/60p: fH 67.50 kHz; fV 60 Hz, 1080/50p: fH 56.25 kHz; fV 50 Hz
	S-Video/Video:	Horizontal: 15.75/15.63 kHz, Vertical: 50/60 Hz, (NTSC, NTSC4.43, PAL, PAL60, PAL-N, PAL-M, SECAM)
Optical axis shift:		Vertical: +50% (powered), horizontal: ±10% (powered)
Keystone correction range:		Vertical: ±40° (±30° with the ET-DLE055)
Installation:		Ceiling/floor, front/rear
Terminals*3:	DVI-D IN:	DVI-D 24-pin x 1, DVI 1.0 compliant, HDCP compatible, for single link only 480p, 576p, 720/60p, 720/50p, 1080/60i, 1080/50i, 1080/24p, 1080/24sF, 1080/25p, 1080/30p, 1080/60p, 1080/50p, VGA (640 x 480)–WUXGA*4 (1,920 x 1,200), compatible with non-interlaced signals only, dot clock: 25–162 MHz
	RGB 1 IN:	BNC x 5
	R, G, B:	R: 0.7 Vp-p, 75 ohms, G: 0.7 Vp-p (G: 1.0 Vp-p for sync on G), 75 ohms, B: 0.7 Vp-p, 75 ohms
	Y, Pb, Pr:	HD/VD, SYNC: High impedance, TTL (positive/negative), 75 ohms Y: 1.0 Vp-p (including sync signal), Pb/Pr: 0.7 Vp-p, 75 ohms NOTE: HD/SYNC, and VD terminals do not accept tri-level sync signals.
	RGB 2 IN:	D-sub HD 15-pin x 1
	R, G, B:	R: 0.7 Vp-p, 75 ohms, G: 0.7 Vp-p (G: 1.0 Vp-p for sync on G), 75 ohms, B: 0.7 Vp-p, 75 ohms
	Y, Pb, Pr:	HD/VD, SYNC: High impedance, TTL (positive/negative), 75 ohms Y: 1.0 Vp-p (including sync signal), Pb/Pr: 0.7 Vp-p, 75 ohms NOTE: HD/SYNC, and VD terminals do not accept tri-level sync signals.

VIDEO IN:	BNC x 1, 1.0 Vp-p, 75 ohms
S-VIDEO IN:	Mini DIN 4-pin x 1, Y: 1.0 Vp-p, C: 0.286 Vp-p, 75 ohms
SERIAL IN:	D-sub 9-pin x 1 (RS-232C compliant) for external controller
SERIAL OUT:	D-sub 9-pin x 1 for link control
REMOTE 1 IN:	M3 jack x 1 for wired remote control
REMOTE 1 OUT:	M3 jack x 1 for link control
REMOTE 2 IN:	D-sub 9-pin x 1 for external control (parallel)
LAN:	RJ-45 x 1 for network connection, 10Base-T/100Base-TX, compliant with PLink™
Power cord length:	3.0 m (9'10")
Cabinet materials:	Molded plastic
Dimensions (W x H x D):	PT-D5000S: 498 mm x 175 mm*4 x 440 mm*5 (19-19/32" x 6-7/8" *4 x 17-5/16" *5) (with supplied lens)
	PT-D5000LS: 498 mm x 175 mm*4 x 432 mm (19-19/32" x 6-7/8" *4 x 17") (without lens)
Weight:	PT-D5000S: Approx. 16.0 kg (35.3 lbs)(with supplied lens)
	PT-D5000LS: Approx. 15.2 kg (33.5 lbs)(without lens)
Operating temperature:	0°–45°C (32°–113°F)
Operating humidity:	20%–80% (no condensation)

Remote Control Unit

Power supply:	3 V DC (AA battery x 2)
Operation range*4:	Approx. 30 m (98.4 feet) when operated from directly in front of the signal receptor
Dimensions (W x H x D):	51 x 176 x 23 mm (2" x 6-15/16" x 29/32")
Weight:	134 g (4.7 oz) (including batteries)

Supplied Accessories

Power cord, Wireless/wired remote control unit, Batteries for remote control (x 2), Wire rope

Optional Accessories

Zoom lens (1.3–2.0:1)	ET-DLE150
Zoom lens (2.4–3.7:1)	ET-DLE250
Zoom lens (3.7–5.6:1)	ET-DLE350
Zoom lens (5.5–8.9:1)	ET-DLE450
Fixed-focus lens (0.8:1)	ET-DLE055
Ceiling mount bracket:	ET-PKD56H (for high ceilings) ET-PKD55S (for low ceilings)

Weights and dimensions shown are approximate. Specifications subject to change without notice.

*1 In Standby mode eco, LAN-based network functions such as the standby ON function will not operate.

*2 Measurement, measuring conditions, and method of notation all comply with ISO 21118 international standards.

*3 The HD/SYNC and VD inputs do not accept the tri-level sync signal.

*4 With legs at shortest position.

*5 Including the supplied lens.

Dimensions

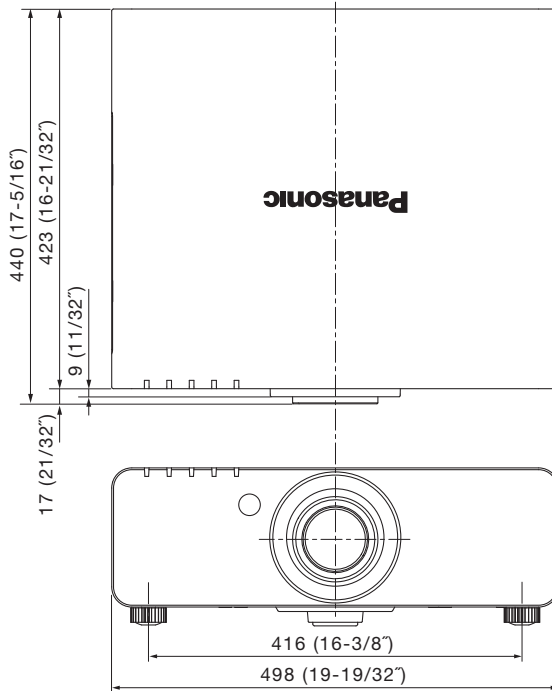

unit : mm (inch)

NOTE: This illustration is not drawn to scale.
The illustration shows the PT-D5000S.

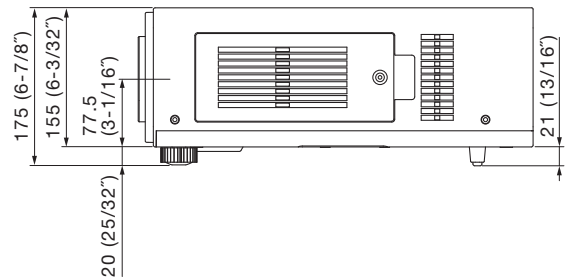

Terminals

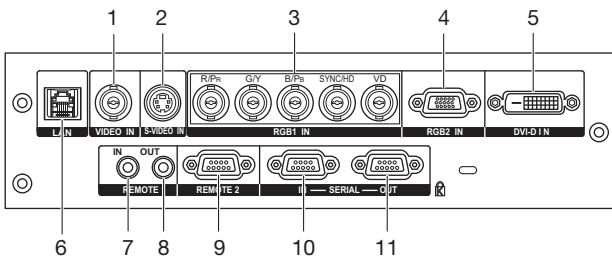

- | | |
|-----------------|-------------------|
| 1 Video input | 7 Remote 1 input |
| 2 S-Video input | 8 Remote 1 output |
| 3 RGB 1 input | 9 Remote 2 input |
| 4 RGB 2 Input | 10 Serial input |
| 5 DVI-D input | 11 Serial output |
| 6 LAN connector | |

Standard setting-up position (when installed using the ET-PKD56H)

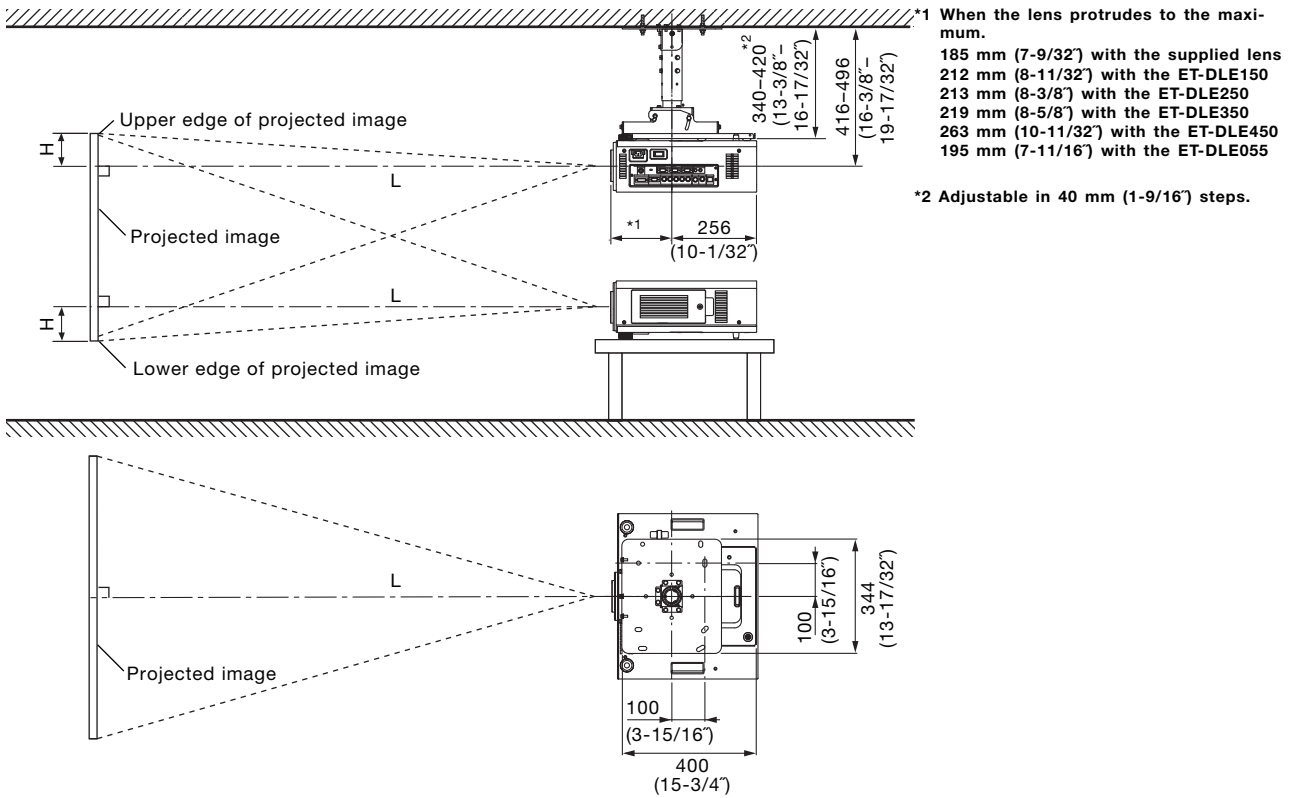

unit : mm (inch)
NOTE: This illustration is not drawn to scale.

Caution:

- All construction work should be done by a qualified technician.
- When mounting to the ceiling, use the special mounting bracket. To prevent the projector from swaying or dropping, attach the wire that is included with the projector between the mounting bracket and the ceiling.

Projection distance for 4:3 aspect ratio screen

Unit: millimeters

Screen size (inch, diagonal)	Distance to screen (L)										Height from the edge of screen to center of lens (H)		
	Zoom										Fixed-focus	Zoom lenses	Fixed-focus lens*
	ET-DLE150 Zoom lens		<i>Supplied lens</i>		ET-DLE250 Zoom lens		ET-DLE350 Zoom lens		ET-DLE450 Zoom lens		ET-DLE055 Fixed-focus lens		
min.	max.	<i>min.</i>	<i>max.</i>	min.	max.	min.	max.	min.	max.				
50	1,344	1,967	<i>1,785</i>	<i>2,376</i>	2,361	3,777	3,713	5,681	5,525	8,912	808	0 – 381	381
60	1,623	2,370	<i>2,155</i>	<i>2,864</i>	2,850	4,548	4,483	6,844	6,690	10,754	979	0 – 457	457
70	1,903	2,773	<i>2,525</i>	<i>3,352</i>	3,338	5,319	5,253	8,007	7,855	12,596	1,150	0 – 533	533
80	2,183	3,177	<i>2,895</i>	<i>3,840</i>	3,826	6,090	6,023	9,170	9,020	14,438	1,322	0 – 610	610
90	2,462	3,580	<i>3,265</i>	<i>4,328</i>	4,315	6,861	6,792	10,333	10,186	16,280	1,493	0 – 686	686
100	2,742	3,983	<i>3,635</i>	<i>4,816</i>	4,803	7,633	7,562	11,496	11,351	18,123	1,664	0 – 762	762
120	3,301	4,790	<i>4,375</i>	<i>5,792</i>	5,779	9,175	9,101	13,823	13,681	21,807	2,006	0 – 914	914
150	4,140	6,000	<i>5,485</i>	<i>7,256</i>	7,244	11,489	11,411	17,312	17,177	27,333	2,519	0 – 1143	1143
200	5,537	8,016	<i>7,335</i>	<i>9,696</i>	9,686	15,344	15,259	23,127	23,004	36,544	3,375	0 – 1,524	1,524
250	6,935	10,033	<i>9,185</i>	<i>12,136</i>	12,127	19,200	19,108	28,943	28,830	45,755	–	0 – 1,905	–
300	8,333	12,049	<i>11,035</i>	<i>14,576</i>	14,568	23,056	22,956	34,758	34,656	54,966	–	0 – 2,286	–
400	11,129	16,082	<i>14,735</i>	<i>19,456</i>	19,451	30,768	30,653	46,389	46,309	73,387	–	0 – 3,048	–
500	13,924	20,115	<i>18,435</i>	<i>24,336</i>	24,334	38,480	38,350	58,020	57,961	91,809	–	0 – 3,810	–
600	16,720	24,148	<i>22,135</i>	<i>29,216</i>	29,217	46,192	46,047	69,651	69,614	110,231	–	0 – 4,572	–

Unit: feet

Screen size (inch, diagonal)	Distance to screen (L)										Height from the edge of screen to center of lens (H)		
	Zoom										Fixed-focus	Zoom lenses	Fixed-focus lens*
	ET-DLE150 Zoom lens		<i>Supplied lens</i>		ET-DLE250 Zoom lens		ET-DLE350 Zoom lens		ET-DLE450 Zoom lens		ET-DLE055 Fixed-focus lens		
min.	max.	<i>min.</i>	<i>max.</i>	min.	max.	min.	max.	min.	max.				
50	4.5	6.5	<i>5.9</i>	<i>7.8</i>	7.8	12.4	12.2	18.7	18.2	29.3	2.7	0.0 – 1.3	1.3
60	5.4	7.8	<i>7.1</i>	<i>9.4</i>	9.4	15.0	14.8	22.5	22.0	35.3	3.3	0.0 – 1.5	1.5
70	6.3	9.1	<i>8.3</i>	<i>11.0</i>	11.0	17.5	17.3	26.3	25.8	41.4	3.8	0.0 – 1.8	1.8
80	7.2	10.5	<i>9.5</i>	<i>12.6</i>	12.6	20.0	19.8	30.1	29.6	47.4	4.4	0.0 – 2.1	2.1
90	8.1	11.8	<i>10.8</i>	<i>14.2</i>	14.2	22.6	22.3	34.0	33.5	53.5	4.9	0.0 – 2.3	2.3
100	9.0	13.1	<i>12.0</i>	<i>15.9</i>	15.8	25.1	24.9	37.8	37.3	59.5	5.5	0.0 – 2.5	2.5
120	10.9	15.8	<i>14.4</i>	<i>19.1</i>	19.0	30.2	29.9	45.4	44.9	71.6	6.6	0.0 – 3.0	3.0
150	13.6	19.7	<i>18.0</i>	<i>23.9</i>	23.8	37.7	37.5	56.8	56.4	89.7	8.3	0.0 – 3.8	3.8
200	18.2	26.3	<i>24.1</i>	<i>31.9</i>	31.8	50.4	50.1	75.9	75.5	119.9	11.1	0.0 – 5.0	5.0
250	22.8	33.0	<i>30.2</i>	<i>39.9</i>	39.8	63.0	62.7	95.0	94.6	150.2	–	0.0 – 6.3	–
300	27.4	39.6	<i>36.3</i>	<i>47.9</i>	47.8	75.7	75.4	114.1	113.8	180.4	–	0.0 – 7.5	–
400	36.6	52.8	<i>48.4</i>	<i>63.9</i>	63.9	101.0	100.6	152.2	152.0	240.8	–	0.0 – 10.0	–
500	45.7	66.0	<i>60.5</i>	<i>79.9</i>	79.9	126.3	125.9	190.4	190.2	301.3	–	0.0 – 12.5	–
600	54.9	79.3	<i>72.7</i>	<i>95.9</i>	95.9	151.6	151.1	228.6	228.4	361.7	–	0.0 – 15.0	–

- The value for L (distance to screen) varies within ±5% depending on the zoom lens characteristics.
- At the shortest projection distance, the zoom lens characteristics may cause slight image distortion.
- When vertical keystone correction is used, the image is corrected in the direction that reduces its projected size.
- The brightness varies depending on the zoom setting.

Calculation of the projection distance

For a screen size different from the above, use the equation below to calculate the projection distance.

Aspect ratio 4:3

ET-DLE150	minimum	$L \text{ (mm)} = (\text{diagonal screen size in inches}) \times 28.0 - 54.0$
	maximum	$L \text{ (mm)} = (\text{diagonal screen size in inches}) \times 40.3 - 49.8$
<i>Supplied lens</i>	<i>minimum</i>	$L \text{ (mm)} = (\text{diagonal screen size in inches}) \times 37.0 - 65.0$
	<i>maximum</i>	$L \text{ (mm)} = (\text{diagonal screen size in inches}) \times 48.8 - 63.8$
ET-DLE250	minimum	$L \text{ (mm)} = (\text{diagonal screen size in inches}) \times 48.8 - 80.0$
	maximum	$L \text{ (mm)} = (\text{diagonal screen size in inches}) \times 77.1 - 79.2$
ET-DLE350	minimum	$L \text{ (mm)} = (\text{diagonal screen size in inches}) \times 77.0 - 135.1$
	maximum	$L \text{ (mm)} = (\text{diagonal screen size in inches}) \times 116.3 - 134.6$
ET-DLE450	minimum	$L \text{ (mm)} = (\text{diagonal screen size in inches}) \times 116.5 - 301.7$
	maximum	$L \text{ (mm)} = (\text{diagonal screen size in inches}) \times 184.2 - 299.1$
ET-DLE055	(fixed focus)	$L \text{ (mm)} = (\text{diagonal screen size in inches}) \times 17.1 - 47.6$

• Distances calculated with the above equations will include a slight error.

Shift range

Optical axis shift function allows to shift the position of a projected image as shown below.

• **Floor mount**

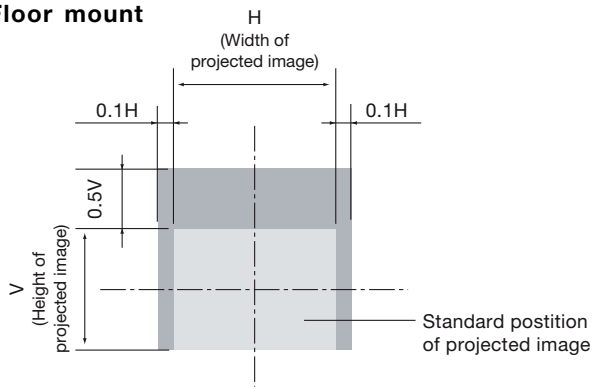

• **Ceiling mount**

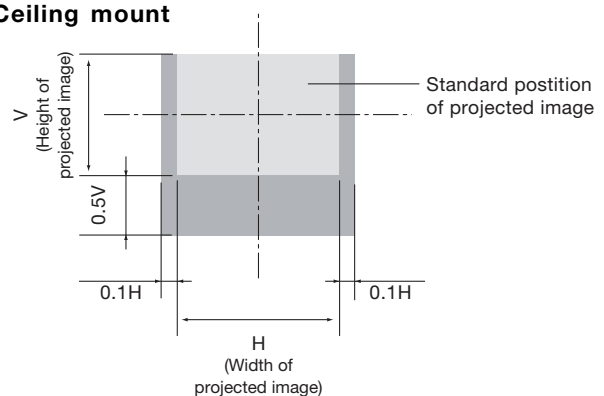

• The ET-DLE055 has a fixed short-focus lens. Therefore, the lens shift function provided in the main unit cannot be used.

Installable angle

Install the projector at an angle within the range shown below.

• **Vertical direction**

The projector may be installed at a vertical angle of 360°.

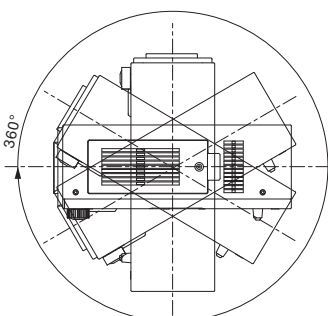

• **Horizontal direction**

The projector may be installed at a horizontal angle of ±10°.

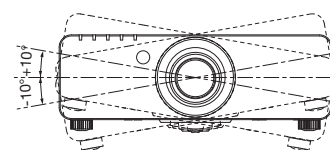

List of compatible signals

The signals that can be input to this projector are shown in the table below. Horizontal scanning frequencies of 15 to 91 kHz, vertical scanning frequencies of 50 to 85 Hz, and a dot clock of 150 MHz maximum (162 MHz maximum for DVI-D signal input) can be input.

NOTE: The native resolution of this projector is 1,024 x 768 pixels. If the display resolution of the input signal is different from the native resolution, image compression or expansion will be used to convert the input signal to a level within the native resolution.

Display mode	Display resolution (dots) ¹	Scanning frequency H (kHz)	Scanning frequency V (kHz)	Dot clock frequency (MHz)	Picture quality ²	Format
NTSC/NTSC4.43/PAL-M/PAL60	720 x 480i	15.7	59.9	–	A	VIDEO/S-VIDEO
PAL/PAL-N/SECAM	720 x 576i	15.6	50.0	–	A	
480i(525i)	720 x 480i	15.7	59.9	13.5	A	YPbPr /RGB
576i(625i)	720 x 576i	15.6	50.0	13.5	A	
480p(525p)	720 x 483	31.5	59.9	27.0	A	YPbPr /RGB/DVI
576p(625p)	720 x 576	31.3	50.0	27.0	A	
720/60p	1,280 x 720	45.0	60.0	74.3	A	
720/50p		37.5	50.0	74.3	A	
1080/60i	1,920 x 1,080i	33.8	60.0	74.3	A	
1080/50i		28.1	50.0	74.3	A	
1080/24p	1,920 x 1,080	27.0	24.0	74.3	A	
1080/24sF	1,920 x 1,080i	27.0	24.0	74.3	A	
1080/25p	1,920 x 1,080	28.1	50.0	74.3	A	
1080/30p		33.8	60.0	74.3	A	
1080/60p		67.5	60.0	148.5	A	
1080/50p		56.3	50.0	148.5	A	
VGA400	640 x 400	31.5	70.1	25.2	A	RGB/DVI
		37.9	85.1	31.5	A	
VGA480	640 x 480	31.5	59.9	25.2	A	
		35.0	66.7	30.2	A	
		37.9	72.8	31.5	A	
		37.5	75.0	31.5	A	
		43.3	85.0	36.0	A	
SVGA	800 x 600	35.2	56.3	36.0	A	
		37.9	60.3	40.0	A	
		48.1	72.2	50.0	A	
		46.9	75.0	49.5	A	
		53.7	85.1	56.3	A	
MAC16	832 x 624	49.7	74.6	57.3	A	
XGA	1,024 x 768	39.6	50.0	51.9	AA	
		48.4	60.0	65.0	AA	
		56.5	70.1	75.0	AA	
		60.0	75.0	78.8	AA	
		65.5	81.6	86.0	AA	
		68.7	85.0	94.5	AA	
		80.0	100.0	105.0	AA	
		96.7	120.0	130.0	AA	
MXGA	1,152 x 864	64.0	71.2	94.2	A	
		67.5	74.9	108.0	A	
		76.7	85.0	121.5	A	
MAC21	1,152 x 870	68.7	75.1	100.0	A	
1280 x 768	1,280 x 768	39.6	49.9	65.3	A	
		47.8	59.9	79.5	A	
1280 x 800	1,280 x 800	41.3	50.0	68.0	A	
		49.7	59.8	83.5	A	
MSXGA	1,280 x 960	60.0	60.0	108.0	A	
SXGA	1,280 x 1,024	64.0	60.0	108.0	A	
		80.0	75.0	135.0	A	
		91.1	85.0	157.5	B	
SXGA+	1,400 x 1,050	64.0	60.0	108.0	A	
		82.2	75.0	155.9	B	
WXGA+	1,440 x 900	55.9	59.9	106.5	A	
UXGA	1,600 x 1,200	75.0	60.0	162.0	B	
WSXGA+	1,680 x 1,050	65.3	60.0	146.3	A	
1920 x 1080 ³	1,920 x 1,080	66.6	59.9	138.5	A	
WUXGA ³	1,920 x 1,200	74.0	60.0	154.0	A	

1. The “i” appearing after the resolution indicates an interlaced signal.

2. The following symbols are used to indicate picture quality.

AA Maximum picture quality can be obtained.

A Signals are converted by the image processing circuit before picture is projected.

B Pixels are thinned (or the image is converted by an image processing circuit for DVI-D signal input) before the picture is projected.

3. WUXGA resolution is supported only when the signals are compliant with VESA CVT-RB (Coordinated Video Timing-Reduced Blanking).

Serial connector

The serial connector complies with RS-232C. To control the projector from a personal computer, commands must be input through communication software, based on the format and satisfying the communication conditions shown below.

Pin assignments and signal names

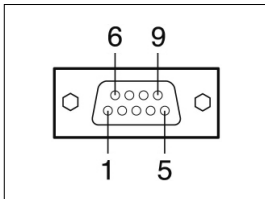

D-sub 9-pin (female)
Serial input

No.	Signal name	Description	No.	Signal name	Description
1	-	NC	6	-	NC
2	TXD	Send data	7	CTS	Connected internally
3	RXD	Receive data	8	RTS	Connected internally
4	-	Connected internally	9	-	NC
5	GND	Ground			

Pin assignments and signal names

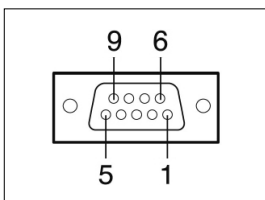

D-sub 9-pin (male)
Serial output

No.	Signal name	Description	No.	Signal name	Description
1	-	NC	6	-	NC
2	RXD	Receive data	7	RTS	Connected internally
3	TXD	Send data	8	CTS	Connected internally
4	-	Connected internally	9	-	NC
5	GND	Ground			

Communication conditions (factory setting)

Signal level	RS-232C-compliant
Synchronization method	Start-stop synchronization
Baud rate	9,600 bps
Parity	None
Character length	8 bits
Stop bit	1 bit
X parameter	None
Y parameter	None

Basic format

Transmission from the computer begins with STX, then the ID, command, parameter, and ETX are sent in this order. Add parameters according to the details of control.

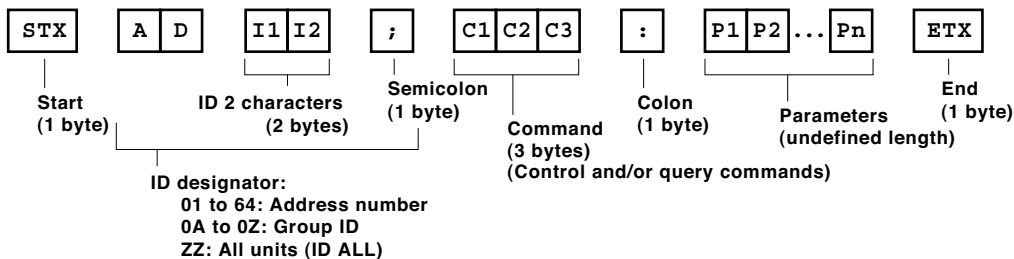

CAUTION

- It may not be possible to send or receive commands for about 10 to 60 seconds when the lamp is first turned on. If this occurs, wait for 60 seconds, then try sending or receiving again.
- When sending multiple commands, be sure to wait for at least 0.5 second after receiving a response from the projector before sending the next command.
- Additional time is sometimes required for response due to processing inside the projector. Set the time-out period for command response to 10 seconds or more.

Cable specifications

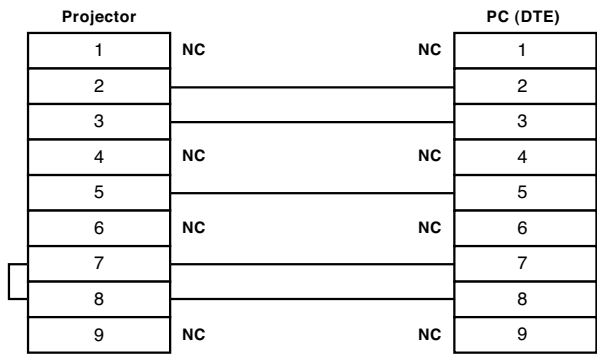

Control commands

Command : Parameter	Function		Callback
PON	POWER (STANDBY)	Standby power on	PON
POF		Standby power off	POF
IIS:DVI	INPUT SELECT	DVI	IIS:DVI
IIS:RG1		RGB 1	IIS:RG1
IIS:RG2		RGB 2	IIS:RG2
IIS:VID		Video	IIS:VID
IIS:SVD		S-Video	IIS:SVD
LPM:0	LAMP SELECT	Dual (two lamps)	LPM:0
LPM:1		Single lamp	LPM:1
LPM:2		Lamp 1	LPM:2
LPM:3		Lamp 2	LPM:3
OSH:0	SHUTTER	Shutter on	OSH:0
OSH:1		Shutter off	OSH:1
OFZ:0	FREEZE	Off	OFZ:0
OFZ:1		On	OFZ:1
OAS	AUTO SETUP		OAS
VPM:NAT	PICTURE MODE	Natural	VPM:NAT
VPM:STD		Standard	VPM:STD
VPM:DYN		Dynamic	VPM:DYN
VPM:CIN		Cinema	VPM:CIN
VPM:GRA		Graphic	VPM:GRA
VXX:DLVI0=+00000	SYSTEM DAYLIGHT VIEW 2	Off	VXX:DLVI0=+00000
VXX:DLVI0=+00001		1	VXX:DLVI0=+00001
VXX:DLVI0=+00002		2	VXX:DLVI0=+00002
VXX:DLVI0=+00003		3	VXX:DLVI0=+00003
OTE:1	COLOR TEMPERATURE	Middle	OTE:1
OTE:2		High	OTE:2
OTE:4		User	OTE:4
OTE:10		Default	OTE:10
TSD:y1y2y3y4m1m2d1d2w	DATE	Date setting	TSD:y1y2y3y4m1m2d1d2w
TST:h1h2m1m2s1s2	TIME	Time setting	TST:h1h2m1m2s1s2
OOS:0	ON SCREEN	On-screen display on	OOS:0
OOS:1		On-screen display off	OOS:1

* Do not send PON, POF, OSH, or OLP commands continuously in a short period of time. Doing so may burst the lamp or shorten the lamp replacement cycle.

* When a command that cannot be executed during standby mode is sent, the projector will send an ER401 command in reply.

Status asking commands

Command:Parameter	Function	Callback	Description
QPW	Standby power status	000	Off
		001	On
QSH	Shutter function status	0	Off
		1	On
QFZ	Freeze function status	0	Off
		1	On
QIN	Input signal status	DVI	DVI
		RG1	RGB 1
		RG2	RGB 2
		VID	Video
		SVD	S-Video
QOS	On-screen display status	0	Off
		1	On
QST	Projector run time	p1p2p3p4p5	00000h-99999h
Q\$L:1	Lamp 1 run time	p1p2p3p4	0000h-9999h
Q\$L:2	Lamp 2 run time	p1p2p3p4	0000h-9999h
QSL	Lamp operation mode status	0	Dual
		1	Single
		2	Lamp 1
		3	Lamp 2
QPM	Picture mode status	NAT	Natural
		STD	Standard
		DYN	Dynamic
		CIN	Cinema
		GRA	Graphic
QVX:DLVI0	System daylight view status	DLVI0=+00000	Off
		DLVI0=+00001	1
		DLVI0=+00002	2
		DLVI0=+00003	3
QTM:0	Temperature status	p1p2p3p4/p5p6p7p8 ^(*1)	p0 = Intake air
QTM:1			p1 = Lamp periphery
QTM:2			p2 = Optical module
QGD	Date setting status	y1y2y3y4m1m2d1d2w	yyyymmdd (day of week) ^(*2)
QGT	Time setting status	h1h2m1m2s1s2	hhmmss ^(*3)

*1 p1p2p3p4: Celsius (°C), p5p6p7p8: Fahrenheit (°F)
 *2 Day of week: Monday = 1, Tuesday = 2, ... Sunday = 7
 *3 Set the date and time to UTC (universal time coordinated).

Command example

To set the on-screen display off, send the command as shown below.

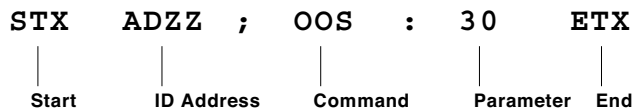

NOTE: When sending commands without parameters, a colon (:) is not necessary.

Notes on Projector Placement and Operation

The projector uses a high-wattage lamp that becomes very hot during operation. Please observe the following precautions.

1. Never place objects on top of the projector while it is operating.
2. Make sure there is an unobstructed space of 500 mm or more around the projector's exhaust openings.
3. Do not stack projector units directly on top of one another. If two units must be stacked for back-up use in ordinary projection, use a method as shown below and provide ample space between the units to ensure that exhaust heat does not accumulate near the intake opening or around the units. Dual stacked projection is not recommended.
4. If the projector is placed in a box or enclosure, ensure the temperature of the air surrounding the projector is between 0°C/32°F and 40°C/104°F*. Also make sure the projector's intake and exhaust openings are not blocked. Take particular care to ensure that hot air from the exhaust openings is not sucked into the intake openings.

* Even when the ambient temperature near the intake opening is 40°C/104°F or lower, an accumulation of hot air inside the cabinet may cause the protective circuit to activate and shut down the projector. Please give ample consideration to the design with regard to ambient temperature conditions.

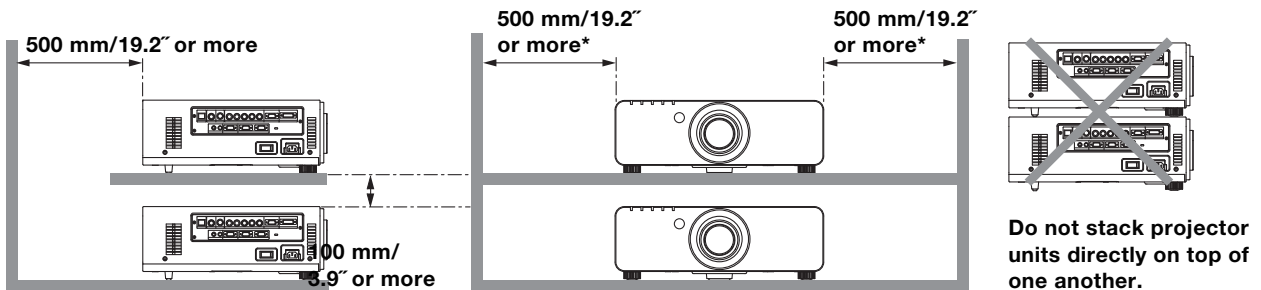

Direction of Air Intake and Exhaust

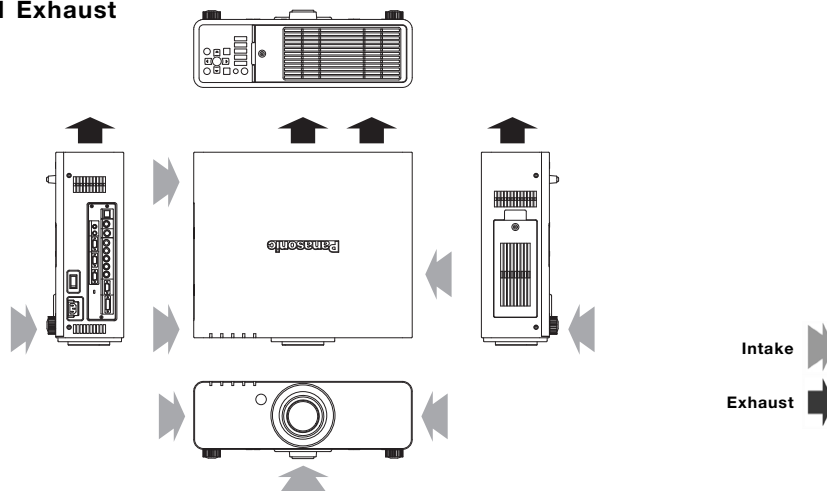

Operating the Projector Continuously

1. If the projector is to be operated continuously 24 hours a day, use the dual-lamp optical system's alternating lamp operation (lamp changer) function. The projector cannot be operated continuously 24 hours a day in dual-lamp mode. Allow a minimum of two hours per day of non-operation time.
2. The lamp replacement cycle duration becomes shorter if the projector is operated repeatedly for short periods.

DLP and the DLP logo are trademarks of Texas Instruments.
 PJLink is a registered trademark, or a trademark application has been filed, in Japan, the United States, and other countries and regions.
 All other trademarks are the property of their respective trademark owners.